



**Technical and Test Institute
for Construction Prague**

Prosecká 811/76a
190 00 Prague
Czech Republic
eota@tzus.cz



Member of



www.eota.eu

European Technical Assessment

**ETA 24/0342
of 03/06/2024**

Technical Assessment Body issuing the ETA: Technical and Test Institute
for Construction Prague

Trade name of the construction product

Q60*10*200, 220, 240, 260, 280, 300 mm
SP STAR STEEL NAIL ANCHOR

**Product family to which the construction
product belongs**

Plastic anchors for fixing of external thermal
insulation composite systems with rendering

Manufacturer

STAR PLASTİK YAPI ELEMANLARI
İZOLASYON, MALZEMELERİ SAN. Ve TİC. A.Ş.
ORTAKÖY MERKEZ MAH.DUMLUPINAR
CADDE NO:44 SİLİVRİ, Istanbul, Turkey

Manufacturing plant(s)

STAR PLASTİK YAPI ELEMANLARI
İZOLASYON, MALZEMELERİ SAN. Ve TİC. A.Ş.
ORTAKÖY MERKEZ MAH.DUMLUPINAR
CADDE NO:44 SİLİVRİ, Istanbul, Turkey

**This European Technical Assessment
contains**

9 pages including 7 Annexes which form an
integral part of this assessment.

**This European Technical Assessment is
issued in accordance with regulation
(EU) No 305/2011, on the basis of**

EAD 330196-01-0604

Translations of this European Technical Assessment in other languages shall fully correspond to the original issued document and should be identified as such.

Communication of this European Technical Assessment, including transmission by electronic means, shall be in full (excepted the confidential Annex(es) referred to above). However, partial reproduction may be made, with the written consent of the issuing Technical Assessment Body - Technical and Test Institute for Construction Prague. Any partial reproduction has to be identified as such.

1. Technical description of the product

The nailed-in plastic anchor Q60*10*200, 220, 240, 260, 280, 300 SP STAR STEEL NAIL ANCHOR consist of an anchor sleeve with plate made of polyethylene, special nail made of galvanized steel as expansion element. The head of the expansion nail has polyethylene coating.

The anchor is expanded by hammering the expansion element into the anchor sleeve. The illustration and the description of the product are given in Annex A.

2. Specification of the intended use in accordance with the applicable EAD

The performances given in Section 3 are only valid if the anchor is used in compliance with the specifications and conditions given in Annex B.

The provisions made in this European Technical Assessment are based on an assumed working life of the anchor of 25 years. The indications given on the working life cannot be interpreted as a guarantee given by the producer, but are to be regarded only as a means for choosing the products in relation to the expected economically reasonable working life of the works.

3. Performance of the product and references to the methods used for its assessment

3.1 Safety in case of fire (BWR 2)

Not assessed based on EAD 330196-01-0604.

3.2 Safety in use (BWR 4)

Essential characteristic	Performance
Characteristic resistance under tension loads	See Annex C 1
Displacement	See Annex C 1
Plate stiffness	See Annex C 1

3.3 Energy economy and heat retention (BWR 6)

Essential characteristic	Performance
Point thermal transmittance	See Annex C 1

4. Assessment and verification of constancy of performance (AVCP) system applied with reference to its legal base

According to the Decision 97/463/EC of the European Commission¹, the system 2+ of assessment verification of constancy of performance (see Annex V to the Regulation (EU) No 305/2011) apply.

5. Technical details necessary for the implementation of the AVCP system, as provided in the applicable EAD

Technical details necessary for the implementation of the AVCP system are laid down in the control plan deposited at Technical and Test Institute for Construction Prague.

Issued in Prague on 03.06.2024

By

Ing. Jiří Studnička, Ph.D.

Head of the Technical Assessment Body



¹ Official Journal of the European Communities L 198/31 25.7.1997

Q60*10 SP STAR STEEL NAIL ANCHOR

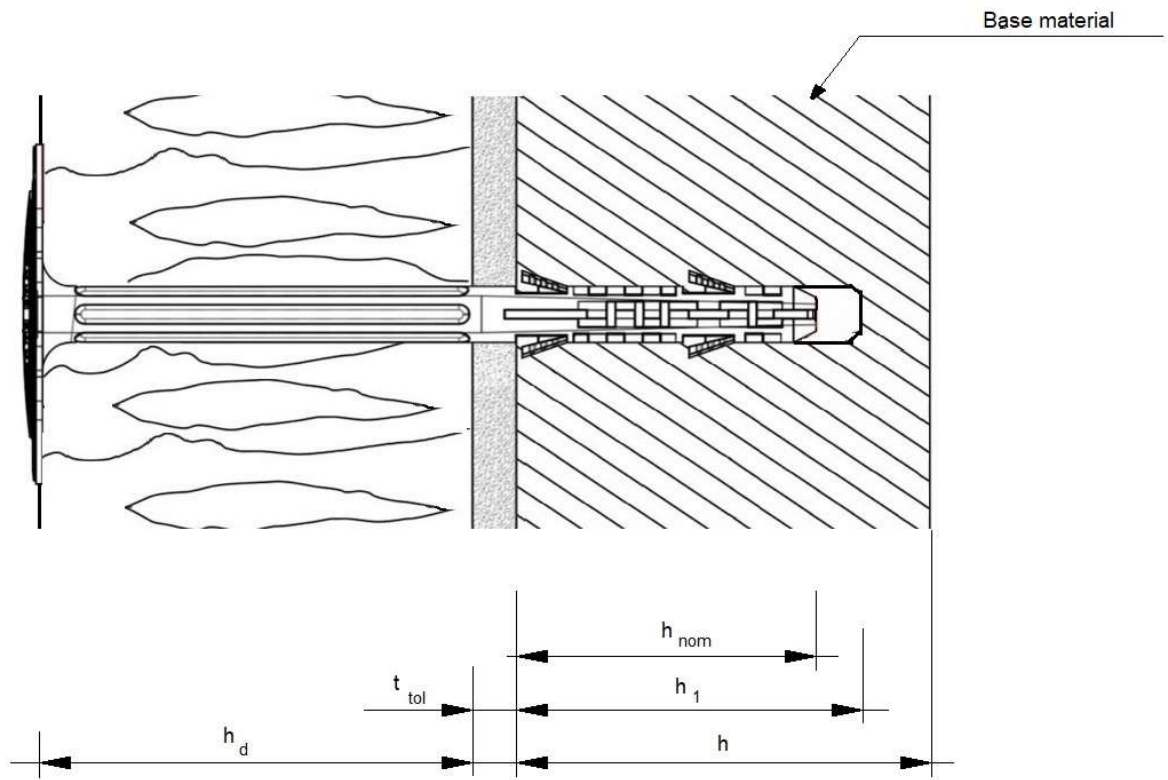

- h_{nom} = overall plastic anchor embedment depth in the base material
- h = thickness of member (wall)
- h_1 = depth of drilled hole to deepest point
- h_d = thickness of insulation material
- t_{tol} = thickness of equalizing layer or non-load-bearing coating

Q60*10*200, 220, 240, 260, 280, 300 SP STAR STEEL NAIL ANCHOR	Annex A 1
Product description Installed conditions	

Q60*10 SP STAR STEEL NAIL ANCHOR
Anchor sleeve

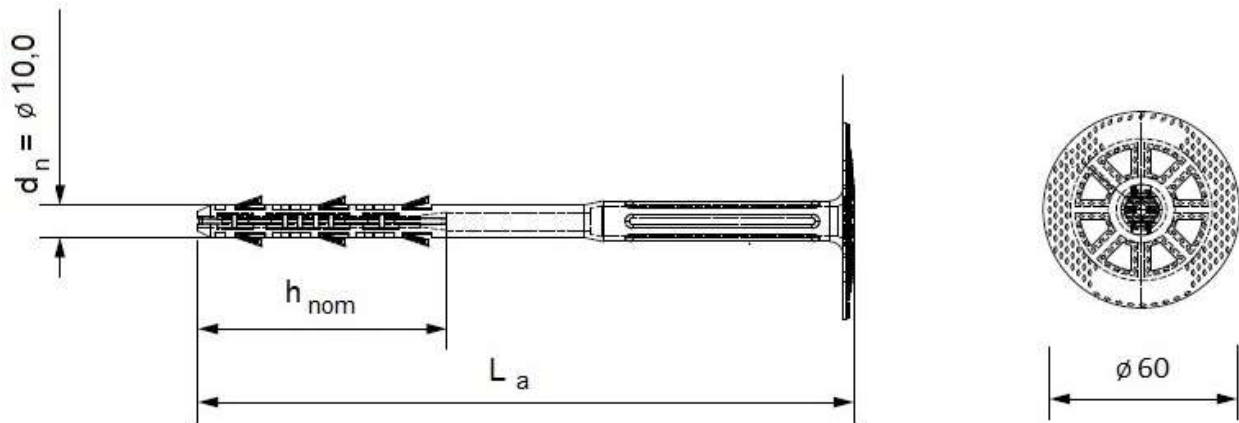

Nail

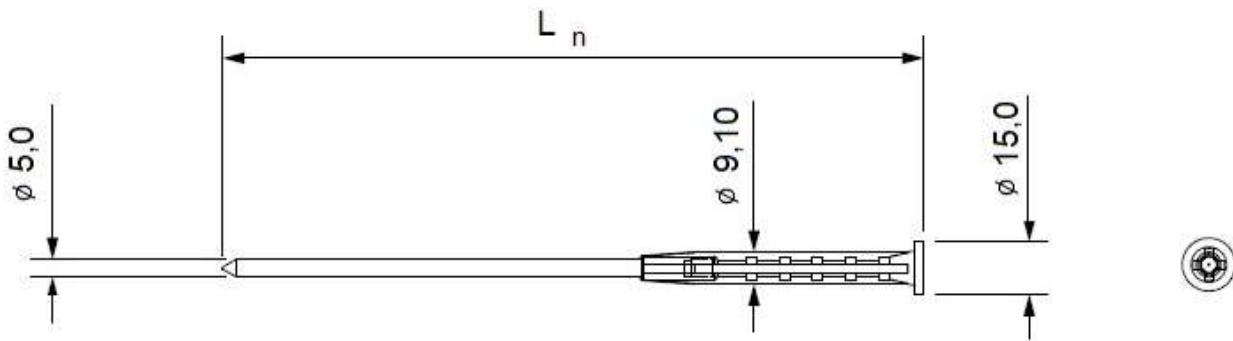

Table A1: Dimensions Q60*10 SP STAR STEEL NAIL ANCHOR

Anchor type	Anchor sleeve			Nail
	$h_{nom} = h_{ef}$ [mm]	$\varnothing d_{nom}$ [mm]	L_a [mm]	L_n [mm]
Use category	A, B, C, D			
Q60*10 SP STAR STEEL NAIL ANCHOR	75	10	200 - 300	198-298

Determination of max. thickness of insulation:

$$h_d = L_a - t_{tol} - h_{nom}$$

Table A2: Materials of anchor Q60*10 SP STAR STEEL NAIL ANCHOR

Designation	Colour	Material
Anchor sleeve	Red	Polyethylene
Expansion nail	Natural	Galvanized steel
Nail plastic cap	Grey	Polyethylene

Q60*10*200, 220, 240, 260, 280, 300 SP STAR STEEL NAIL ANCHOR

Product description
Dimensions
Materials

Annex A 2

Specifications of intended use

Anchorage subject to:

- Multiple fixing for the anchorage of bonded thermal insulation composite systems (ETICS).

Base materials

- Reinforced or unreinforced normal weight concrete (Use category A), according to Annex B 3.
- Solid brick (Use category B), according to Annex B 3.
- Perforated clay brick (Use category C), according to Annex B 3.
- Lightweight aggregate concrete blocks - LAC (Use category D), according to Annex B 3.
- The characteristic tension resistance of the anchor may be determined by means of job site tests according to EOTA TR 051, edition December 2016, carried out on the material actually used, if a characteristic resistance of the base material does not exist (for example masonry made of other solid masonry units or made of perforated clay bricks).

Use conditions

- The anchor may only be used for transmission of wind suction loads and shall not be used for the transmission of dead loads of the thermal insulation composite system. The dead loads have to be transmitted by the bonding of the thermal insulation composite system.

Use categories:

- A, B, C and D.

Design:

- The anchorages are designed under the responsibility of an engineer experienced in anchorages and masonry work with the partial safety factors for material related resistances $\gamma_M = 2,0$ and for action loads $\gamma_F = 1,5$ in absence of other national regulations.
- Verifiable calculation notes and drawings shall be prepared taking account of the loads to be anchored, the nature and strength of the base materials, the thickness of insulation and the dimensions of the anchorage as well as of the relevant tolerances.
- Proof of direct local application of load on the base material shall be delivered. The anchor shall only be used for the transmission of wind suction loads. All other loads such as dead load and restraints shall be transmitted by the adhesion of the relevant external thermal insulation composite system.

Q60*10*200, 220, 240, 260, 280, 300 SP STAR STEEL NAIL ANCHOR

Intended use
Specifications





Annex B 1

Installation:

The fitness for use of the anchor can only be assumed if the following conditions of installation are met:

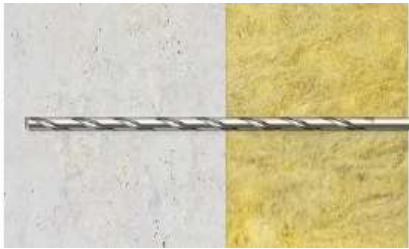
- Anchor installation carried out by appropriately qualified personnel under the supervision of the person responsible for technical matters on site.
- Observation of the drill method (Drill holes in masonry made of perforated clay bricks and lightweight aggregate concrete blocks (LAC) may only be drilled using the rotary drill. Other drilling methods may also be used if job-site tests evaluate the influence of hammer or impact drilling.)
- Placing drill holes without damaging the reinforcement
- Temperature during installation of the anchor $\geq 0^{\circ}\text{C}$.
- Exposure to UV due to solar radiation of the anchor not protected by rendering 6 weeks.

Installation instructions

1.		Drill hole perpendicular to substrate surface.
3.		Bottom side of the plate must be flush with the ETICS
4.		Use the hammer for proper installation
5.		Assembled condition of anchor

Q60*10*200, 220, 240, 260, 280, 300 SP STAR STEEL NAIL ANCHOR

Intended use
Installation
Installation instructions

Annex B 2

Types of base materials

Table B1: Base materials Q60*10 SP STAR STEEL NAIL ANCHOR

Base material	Use category	Bulk density [kg/dm ³]	Min. compressive strength f_c [N/mm ²]	General remarks	Drilling method
Concrete C 12/15 according to EN 206-1	A				Hammer drilling
Concrete C 16/20 – C 50/60 according to EN 206-1	A				Hammer drilling
Solid clay bricks according to EN 771-1	B	$\geq 2,0$	20	Vertical perforation up to 15%	Hammer drilling
Vertical perforated clay bricks POROTHERM 17,5 P+D according to EN 771-1	C	$\geq 0,9$	15	Vertical perforation more than 15% and less than 50% with outer web thickness ≥ 11 mm	Only rotary drilling
Lightweight aggregate concrete blocks LAC according to EN 1520	D	$\geq 1,2$	4		Only rotary drilling

Q60*10*200, 220, 240, 260, 280, 300 SP STAR STEEL NAIL ANCHOR

Intended use
Base materials

Annex B 3

Installation

Table B2: Installation characteristics

Anchor type	Q60*10 SP STAR STEEL NAIL ANCHOR	
Use category	A, B, C, D	
Nominal diameter of drill bit	d_o [mm]	10
Min. diameter of drill bit	$d_{cut, min} \geq$ [mm]	10,2
Max. diameter of drill bit	$d_{cut, max} \leq$ [mm]	10,4
Depth of drill hole	$h_1 \geq$ [mm]	85
Effective embedment depth	$h_{ef} \geq$ [mm]	75

Table B3.1: Minimum thickness of base material, edge distance and anchor spacing

Anchor type	Minimum thickness of base material h [mm]	Minimum spacing s_{min} [mm]	Minimum edge distance c_{min} [mm]
Q60*10 SP STAR STEEL NAIL ANCHOR	100	100	100

Scheme of distance and spacing.

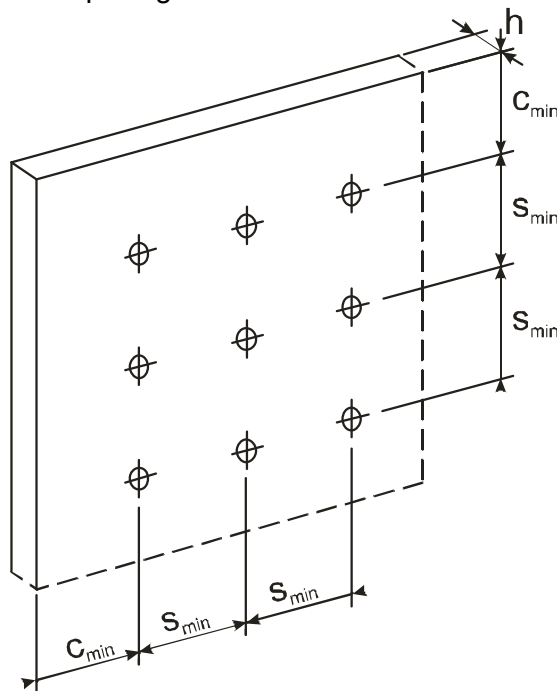

Q60*10*200, 220, 240, 260, 280, 300 SP STAR STEEL NAIL ANCHOR

Intended use
Installation characteristics
Edge and axial distances

Annex B 4

Table C1: Characteristic resistance to tension loads for single anchor

Base material	Use category	Bulk density [kg/dm ³]	Min. compressive strength β [N/mm ²]	Q60*10 SP STAR STEEL NAIL ANCHOR [kN]
Concrete C 12/15 according to EN 206-1	A			0,45
Concrete C 16/20 – C 50/60 according to EN 206-1	A			0,65
Solid clay bricks according to EN 771-1	B	$\geq 2,0$	20	0,60
Vertical perforated clay bricks POROTHERM 17,5 P+D according to EN 771-1	C	$\geq 0,9$	15	0,25
Lightweight aggregate concrete hollow blocks LAC according to EN 1520	D	$\geq 1,2$	4	0,50
Partial safety factor	$\gamma_M^{1)}$	2,0		

¹⁾ In the absence of other national regulations

Table C2: Displacement under tension loads

Base material	Tension load N_{Sk} [kN]	Displacement $\Delta\delta_N$ [mm]
Concrete C 12/15 according to EN 206-1	0,15	0,43
Concrete C 16/20 – C 50/60 according to EN 206-1	0,22	0,43
Solid clay bricks according to EN 771-1	0,20	0,50
Vertical perforated clay bricks POROTHERM 17,5 P+D according to EN 771-1	0,08	0,31
Lightweight aggregate concrete hollow blocks LAC according to EN 1520	0,16	0,47

Table C3: Plate stiffness

Anchor type	Diameter of the anchor plate [mm]	Load resistance of the anchor plate [kN]	Plate stiffness [kN/mm]
Q60*10 SP STAR STEEL NAIL ANCHOR	60	1,11	0,30

Table C4: Point thermal transmittance

Anchor type	Insulation thickness h_D [mm]	Point thermal transmittance χ [W/K]
Q60*10 SP STAR STEEL NAIL ANCHOR	< 150	0,002
	≥ 150	0,001

Q60*10*200, 220, 240, 260, 280, 300 SP STAR STEEL NAIL ANCHOR

Performances

Characteristic tension load, Displacement under tension load
Plate stiffness, Point thermal transmittance

Annex C 1